

■ Repair Kit KK-4987-2

## MSV-531 HIGH VOLUME LOW PRESSURE SPRAY GUN

**IMPORTANT: Before using this equipment, read all Safety Precautions and Instructions. Retain for future use.**

### DESCRIPTION

The MSV-531 is a slightly smaller, lighter HVLP spray gun, capable of high production. It can be used with a wide variety of finishing materials. All models are designed to provide maximum transfer efficiency by **limiting air cap pressure to 10 psi (complies with rules issued by SCAQMD and other air quality authorities)**. The gun is intended for use with pressure feed paint supply only.

#### Note

The MSV-531 spray gun is not suitable for highly abrasive materials (i.e. porcelain enamel, certain mica paints, etc.). Premature fluid tip and needle wear will occur. We recommend carboloy fluid tips (AV-617 series) and needles (JGA-409 series) for use with these coatings.

Most finishing materials can be atomized with the 28 or 33A air caps. The 28 or 33A air caps should be used where possible as they consume less air volume (CFM) and have slightly better transfer efficiency than the 46MP and 83MP air caps. However, more difficult to atomize materials (i.e. low VOC's) or high flow applications (over 12 oz./min.), are ideal for the 46MP (maximum performance) air cap, fluid tip and baffle combination. Also available is the 83MP (maximum performer) for even higher flows (17 oz./min. and above), and viscosities. Refer to the air cap chart for more information. Spray guns with a 28 or 33A nozzle combination can be converted to 46MP or 83MP if desired.

### AIR CAPS - PATTERNS - APPLICATIONS

Air Cap No.	*Typical Pattern Size and Shape	Typical Application
28	11" long, straight-sized, similar to #704 air cap.	Most common finishing materials up to 12 oz./min.
33A	9" long, tapered ends similar to #30 air cap.	
46MP	11" long, straight-sided, similar to #704 air cap.	Low VOC materials, 12 to 16 oz./min.
83MP	13" long, straight-sides, similar to #765 air cap.	Low VOC materials, 17 oz./min. and above.

\*Actual pattern length dependent upon fluid tip ID, fluid flow rate, viscosity, air pressure, and fan pressure.

### Operating Pressures:

Air: 100 PSI Maximum (see following chart)  
 Fluid: 150 PSI Maximum

### Standard Combinations Available:

Order No.	* Gun Inlet Pressure
MSV-531-28FF, FX	50 PSI
MSV-531-33FF, FX	50 PSI
MSV-531-46FF, FX	50 PSI
MSV-531-83D, E	65 PSI
*MSV-531-3-46FF, FX	50 PSI

• Models include 300 grade stainless fluid tip with UHMW poly. needle seat and 300 stainless needle.

\* Approximate pressure required to achieve 10 PSI air cap pressure.

Gun models are available with 400 grade stainless fluid tips and 300 series stainless needles, and are suitable for most common coating materials. Select model combinations (see above) are available with 300 grade stainless fluid tips and needles, and can be used with waterborne materials or more corrosive coatings (6.0 pH or above).

These gun models will produce approximately 10 psi cap pressure at the corresponding gun inlet pressure, as measured at the gun inlet. Air cap test kits (see Accessories) should be used to insure 10 psi air cap pressure is not exceeded.

#### Note

This gun may be used with chlorinated solvents; but, see additional warnings on page 2.

### INSTALLATION

**Do not use more pressure than is necessary to atomize the material being applied.** To provide optimum performance and assure compliance with all air quality regulations, an air cap test gauge kit is available to determine actual air cap pressures being used. See Accessories.

Connect the gun to a clean, moisture and oil free air supply using a hose size of at least **5/16" I.D. hose. Avoid use of quick detachable connectors.** Do not use 1/4" ID hose (25' x 1/4" hose at 18 CFM has a pressure loss of 25 psi. 25' x 5/16" hose at 18 CFM has a pressure loss of 8.1 psi).

### Note

Depending on hose length, larger hose I.D. may be required. Install an HAV-501 air gauge at the gun handle and air cap test kit over tip. When gun is triggered on, adjust regulated pressure to desired setting to provide a maximum of 10 psi at the air cap. **Do not use more pressure than is necessary to atomize the material being applied.**

### OPERATION

Adjust fluid pressure to deliver the desired paint volume. Refer to the next paragraph also on "Back Pressure". Adjust air pressure and flow to provide a uniform dispersion of atomized paint throughout the pattern. Excessive flow rates will result in heavy center spray patterns. Inadequate flows may cause the pattern to split. See Spray Gun Guide, SB-2-001 latest revision, for details concerning set up of spray guns.

### Back Pressure - 46MP & 83MP "Maximum Performer"

Due to the unique cone shape of the MP fluid tips, a slight back pressure is created against the fluid column. This will reduce the amount of fluid output. To compensate, increase the fluid regulator pressure slightly. With 10 PSI cap pressure, back pressures are approximately 3.5 PSI with the 46MP and 2.0 PSI with the 83MP.

HVLP requires gun distances of 6-8" be used. Excess distance will produce inferior results. Strain material through 60 or 90 mesh screen.

### PREVENTIVE MAINTENANCE

#### Note

If baffle (6) is removed for any reason, replace the o-ring (5). To prevent damage to the o-ring during installation, apply SSL-10 gun lube to exterior of o-ring (5) and ID of baffle.

To clean air cap and fluid tip, brush exterior with a stiff bristle brush. If necessary to clean cap holes, use a broom straw or toothpick. **Never use a wire or hard instrument.** This may scratch or burr holes causing a distorted spray pattern.

To clean fluid passages, remove excess material at source, then flush with a suitable solvent using a device such as the SolventSaver™ (see Accessories). Wipe gun exterior with a solvent dampened cloth.

(continued on page 3)

**SAFETY PRECAUTIONS**

This manual contains information that is important for you to know and understand. This information relates to USER SAFETY and PREVENTING EQUIPMENT PROBLEMS. To help you recognize this information, we use the following symbols. Please pay particular attention to these sections.

**WARNING**

**Important safety information - A hazard that may cause an injury or loss of life.**

**CAUTION**





**Important information that tells how to prevent damage to equipment.**

**Note**

Information that you should pay special attention to.

**WARNING**

**The following hazards may occur during the normal use of this equipment.  
Please read the following chart before using this equipment.**

HAZARD	CAUSE	SAFEGUARD
<b>Fire</b> 	Solvent and coatings can be highly flammable or combustible, especially when sprayed.	Adequate exhaust must be provided to keep air free of accumulations of flammable vapors.  Smoking must never be allowed in the spray area.  Fire extinguishing equipment must be present in the spray area.
<b>Solvent Spray</b> 	During cleaning and flushing, solvents can be forcefully expelled from fluid and air passages. Some solvents can cause eye injury.	Wear eye protection.
<b>Inhaling Toxic Substances</b> 	Certain materials may be harmful if inhaled, or if there is contact with skin.	Follow the requirements of the Material Safety Data Sheet supplied by your coating material manufacturer.  Adequate exhaust must be provided to keep the air free of accumulations of toxic materials.  Use a mask or respirator whenever there is a chance of inhaling sprayed materials. The mask must be compatible with the material being sprayed and its concentration. Equipment must be as prescribed by an industrial hygienist or safety expert, and be NIOSH approved.
<b>Explosion Hazard - Incompatible Materials</b> 	Halogenated hydrocarbon solvents - for example; methylene chloride and 1, 1, 1 - Trichloroethane can chemically react with aluminum. The chemical reaction caused by these solvents reacting with aluminum can become violent and lead to an equipment explosion.	Guns with stainless steel internal passageways may be used with these solvents. However, aluminum is widely used in other spray application equipment - such as material pumps, regulators, valves & cups. Check all equipment items before use and make sure they can also be used safely with these solvents. Read the label or data sheet for the material you intend to spray. If in doubt as to whether or not a coating or cleaning material is compatible, contact your material supplier.
<b>General Safety</b>	Improper operation or maintenance of equipment.	Operators should be given adequate training in the safe use & maintenance of the equipment (in accordance with the requirements of NFPA-33, Chapter 15). Users must comply with all local & national codes of practice and insurance company requirements governing ventilation, fire precautions, operation, maintenance and housekeeping. These are OSHA Sections 1910.94 and 1910.107 and NFPA-33.
<b>Cumulative Trauma Disorders "CTD's"</b>  <b>CTD's, or musculoskeletal disorders, involve damage to the hands, wrists, elbows, shoulders, neck and back. Carpal tunnel syndrome and tendinitis (such as tennis elbow or rotator cuff syndrome) are examples of CTD's</b>	Use of hand tools may cause cumulative trauma disorders "CTD's".  CTD's, when using hand tools, tend to affect the upper extremities. Factors which may increase the risk of developing a CTD include: <ol style="list-style-type: none"> <li>1. High frequency of the activity.</li> <li>2. Excessive force, such as gripping, pinching or pressing with the hands and fingers.</li> <li>3. Extreme or awkward finger, wrist, or arm positions.</li> <li>4. Excessive duration of activity.</li> <li>5. Tool vibration.</li> <li>6. Repeated pressure on a body part.</li> <li>7. Working in cold temperatures.</li> </ol>	Pain, tingling, or numbness in the shoulder, forearm, wrist, hands or fingers, especially during the night, may be early symptoms of a CTD. Do not ignore them. Should you experience any such symptoms, see a physician immediately. Other early symptoms may include vague discomfort in the hand, loss of manual dexterity, and nonspecific pain in the arm. Ignoring early symptoms and continued repetitive use of the arm, wrist and hand can lead to serious disability. Risk is reduced by avoiding or lessening factors 1-7.

Never completely immerse in solvent as this is detrimental to the lubricants and packings.

**FLUID INLET GASKET (7) REPLACEMENT INSTRUCTIONS**

1. Remove fluid inlet adapter with appropriate wrench.
2. Clean Loctite from gun body inlet threads and seal area.
3. Place gasket (7) squarely onto the fluid inlet adapter and push it down until it is flat against the boss.
4. Place a couple of drops of thread sealant (i.e. Loctite 242, med, strength, Blue or equal) on threads before installing fluid inlet adapter.
5. Torque fluid inlet adapter 25-30 ft. lbs. and tighten locknut.

**CAUTION**

To prevent damage to the fluid tip (3) or fluid needle (30), be sure to either 1) pull the trigger and hold while loosening or tightening the fluid tip or 2) remove fluid needle adjusting screw (34) to relieve spring pressure against needle collar.

**Note**

When replacing the fluid tip or fluid needle, replace both at the same time. Using worn parts can cause fluid leakage. Lapped sets are available for most pressure feed combinations. See Chart 2. Also, replace the needle packing (22) at this time. Lightly lubricate the threads of the fluid tip before reassembling. Torque to 20-25 ft. lbs. Do not overtighten the fluid tip.

If the air cap is changed, the **baffle must also be changed**. Use of incorrect baffle and cap set will result in substandard performance and or improper air cap pressures. See Chart 1 for ordering information.

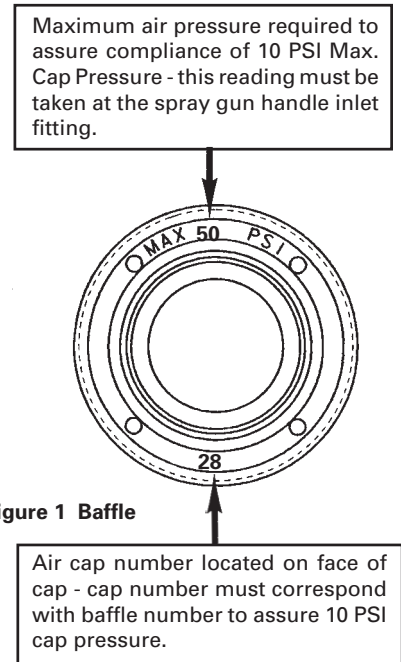

Figure 1 Baffle

**CHART 1**

AIR CAP & BAFFLE COMBINATIONS								
No. Stamped on Parts		Set		CFM @ Cap Pressure				
Air Cap Part No.	Baffle	Ref. No. 2 Air Cap	Ref. No. 6 Baffle	2 PSI	4 PSI	6 PSI	8 PSI	10 PSI
33A	33-50	JGHV-101-33A	JGHV-450-33-50	8.25	11.75	14.5	16.75	18.75
46MP	46-50	JGHV-101-46MP	JGHV-450-46-50	8.5	13.0	16.5	19.75	22.5
83MP	83-65	JGHV-101-83MP	JGHV-450-83-65	10.0	15.5	19.5	23.0	26.0

**CHART 2**

FLUID TIPS AND NEEDLES			
If this is No. on Tip, Order →	Ref. No. (3)* Fld. Tip & Gasket	Ref. No. (30) Fluid Needle	Matched Tip & Needle Set
<b>400 Gr. Stainless Steel Tip/303 Stainless Steel Needle (Standard)</b>			
AV-2115-FF (.055")	→	→	JGA-4040-FF
AV-2115-FX (.042")	→	→	JGA-4040-FX
AV-2120-FF (.055")**	→	→	JGA-4045-FF
AV-2120-FX (.042")**	→	→	JGA-4045-FX
AV-2120-D (.086")***	→	→	JGA-4045-D
AV-2120-E (.070")***	→	→	JGA-4045-E
<b>303 Grade Stainless Steel w/U.H.M.W. Poly. Needle Seat (Optional)</b>			
AV-4915-D (.086")	→	→	JGA-4056-D
AV-4915-E (.070")	→	→	JGA-4056-E
AV-4915-FF (.055")	→	→	JGA-4056-FF
AV-4915-FX (.042")	→	→	JGA-4056-FX
AV-4920-D (.086")***	→	→	JGA-4051-D
AV-4920-E (.070")***	→	→	JGA-4051-E
AV-4920-FF (.055")**	→	→	JGA-4051-FF
AV-4920-FX (.042")**	→	→	JGA-4051-FX

\* Do not use AV-1 gasket with this spray gun.  
 \*\* For use with 46MP air cap.  
 \*\*\* For use with 83MP air cap.

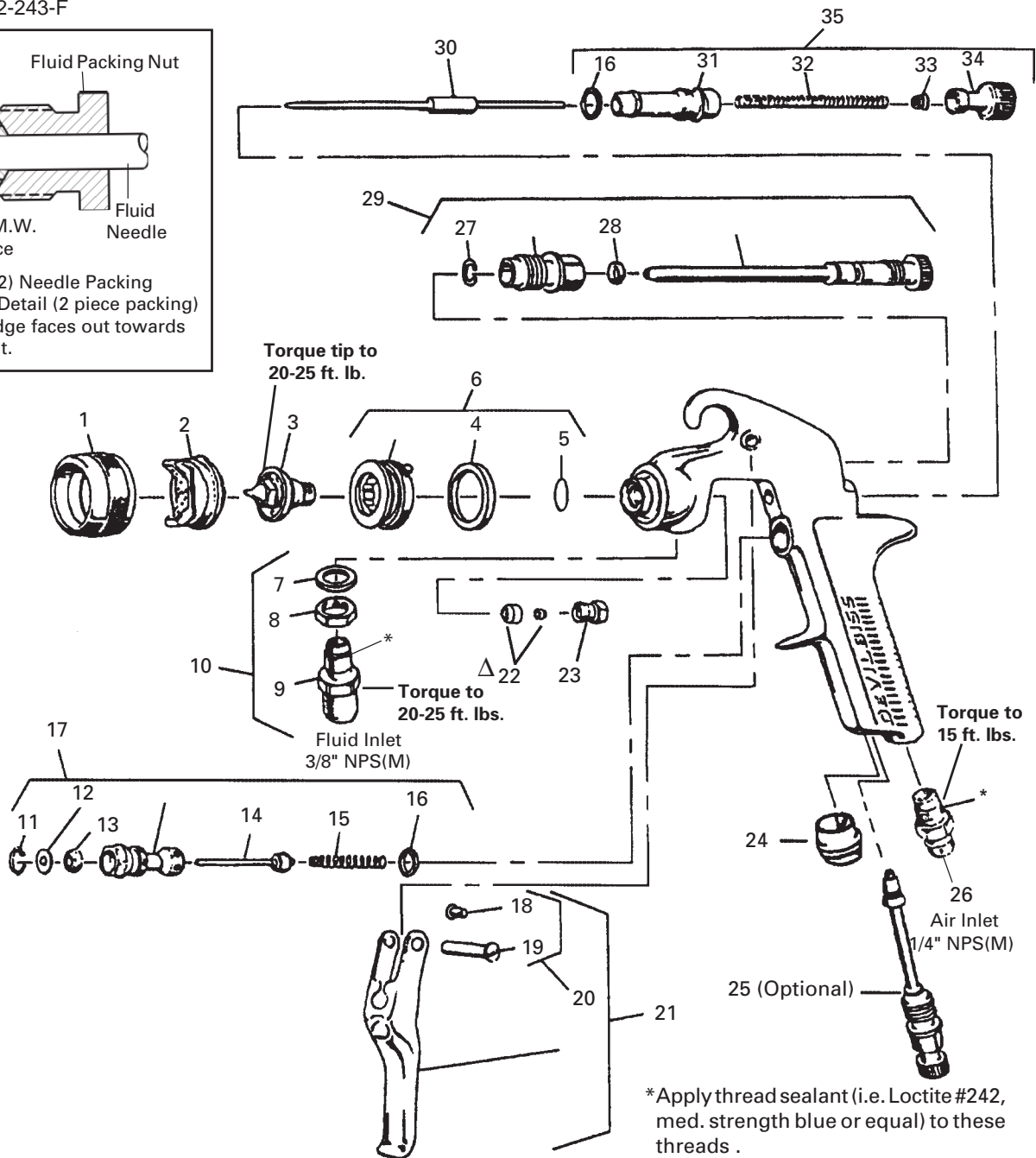
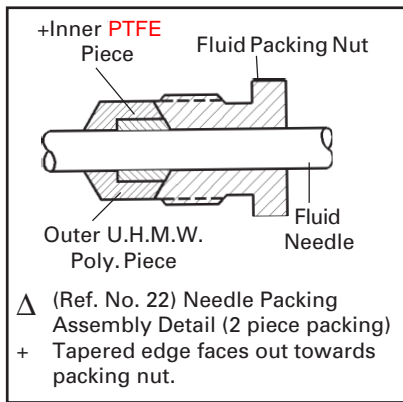

**PARTS LIST**

Ref. No.	Replacement Part No.	Description	Individual Parts Req.
1	MSA-1	Retaining Ring (Delrin) .....	1
2	See Chart 1	Air Cap .....	1
3	See Chart 2	Fluid Tip .....	1
•4	JGD-14-K10	Seal (Kit of 10) (Polyethylene) .....	1
•#5	SSG-8182-K5	O-Ring (Kit of 5) (Buna-N) .....	1
6	See Chart 1	Baffle, Seal & O-Ring Kit .....	1
7	MSV-3-K10	Gasket Kit (Kit of 10) (blue) .....	1
8	---	Locknut .....	1
9	---	Fluid Inlet Adapter 3/8" NPS(m) ...	1
10	JGA-4044	Fluid Inlet & Nut Kit .....	1
•11	JGA-14-K25	Snap Ring .....	1
•12	JGA-15-K25	Washer .....	1
•#13	JGS-26-K25	"U" Cup .....	1
•14	JGS-431-K25	Air Valve .....	1
•15	MBD-12-K25	Spring .....	1
•#16	JGS-72-K10	Gasket (Kit of 10) (PTFE ) .....	2
17	JGS-449-1	Air Valve Assembly .....	1
•18	---	Screw .....	1
19	---	Trigger Bearing Stud .....	1
20	JGS-478	Stud & Screw Kit .....	1
21	JGS-477-1	Trigger, Stud & Screw Kit .....	1
		(Kit includes 1 each)	

Ref. No.	Replacement Part No.	Description	Individual Parts Req.
•#22	JGV-463-K3	Fluid Needle Packing Kit (Kit of 3) .....	1
23	34411-122-K10	Fluid Needle Packing Nut (Kit of 10) ..	1
24	JGA-132	Plug .....	1
25	JGA-4005	Air Adjusting Valve (Optional) .....	1
26	MSA-3	Connector 1/4" NPS .....	1
•27	---	Retaining Ring .....	1
•#28	SSG-8069-K25	O-Ring Kit (Kit of 25) (Viton) .....	1
29	JGA-497-1	Air Valve Assembly - Horn .....	1
30	See Chart 2	Fluid Needle .....	1
31	---	Gun Body Bushing .....	1
•32	MBD-19-K10	6# Spring (Kit of 10) .....	1
	MSA-4-K10	4# Spring (Kit of 10) (optional) .....	1
33	---	Spring Pad (included with #32) .....	1
34	JGS-16	Fluid Needle Adjusting Screw .....	1
35	JGA-4041	Bushing, Spring & Knob Kit .....	1

• These parts included in primary service Gun Repair Kit ■ KK-4987-2. This kit should be kept on hand for service convenience.

# A quantity of necessary parts is included in Minor Repair Kit KK-5034 for gun repair.

Δ Two Piece Packing covered by U.S. Patent No. 5,209,501. Other patents pending.

■ Government NSN No. 4940-01-046-9919 = KK-4987-2

**SPRAY GUN LUBRICATION**

Daily, apply a drop of •SSL-10 at trigger bearing stud (19) and the stem of the air valve assembly (14) where it enters the air valve assembly (17). The shank of the fluid needle (30) where it enters the packing nut (23) should also be oiled. The fluid needle packing (22) should be lubricated also. **Make sure baffle (6) and retaining ring (1) threads are clean and free of foreign matter. Before assembling air cap to baffle, clean the retaining ring and baffle threads thoroughly, then add two drops of •SSL-10 spray gun lube to threads.**



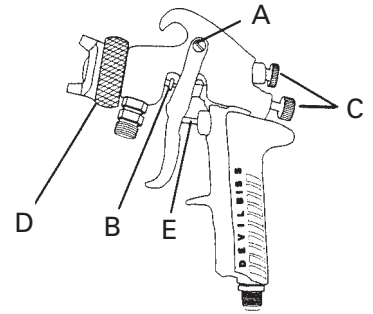

The fluid needle spring (32) and air valve spring (15) should be coated on the ends with a light grease, ensuring that any excess grease will not clog the air passages. For best results, lubricate the points indicated daily using •SSL-10 spray gun lube.

- A. Trigger points
- B. Packing
- C. Adjusting valves
- D. Baffle & retaining ring threads
- E. Air valve cartridge



• Material safety data sheet available from DeVilbiss upon request.

**TROUBLESHOOTING**

CONDITION	CAUSE	CORRECTION
<b>Heavy top or bottom pattern</b> 	Horn holes plugged. Obstruction on top or bottom of fluid tip. Cap and/or tip seat dirty.	Clean. Ream with nonmetallic point. Clean. Clean.
<b>Heavy right or left side pattern</b> 	Left or right side horn holes plugged. Dirt on left or right side of fluid tip.  Remedies for top-heavy, bottom-heavy, right-heavy and left-heavy patterns: 1) Determine if obstruction is on cap or fluid tip. Do this by making a test pattern. Then, rotate cap one-half turn and spray another pattern. If defect is inverted, obstruction is on air cap. Clean air cap as previously instructed. 2) If defect is not inverted, it is on fluid tip. Check for a fine burr on edge of fluid tip. Remove with #600 wet or dry sand paper. 3) Check for dried material just inside opening. Remove by cleaning.	Clean. Ream with nonmetallic point. Clean.
<b>Heavy center pattern</b> 	Material flow exceeds air cap's capacity. Atomizing pressure too low. Material too thick.	Thin or lower fluid flow. Increase pressure. Thin to proper consistency.
<b>Split spray pattern</b> 	Fluid adjusting knob turned in too far. Atomization air pressure too high.	Back out counterclockwise to achieve proper flow. Reduce air pressure.
<b>Jerky or fluttering spray</b> 	*Loose or damaged fluid tip /seat. Material level too low. Container tipped too far. Obstruction in fluid passage. Loose or broken fluid tube or fluid inlet nipple. Dry or loose fluid needle packing nut.	Tighten or replace. Refill. Hold more upright. Clean according to material supplier's recommendations. Tighten or replace. Lubricate or tighten.
<b>Will not spray</b>	No air pressure at gun. Fluid needle adj. screw not open enough. Fluid pressure too low with internal mix cap and pressure tank.	Check air supply and air lines. Open fluid needle adjusting screw. Increase fluid pressure at tank.
<b>Excessive overspray</b>	Too much atomization air pressure. Gun too far from work surface. Improper stroking (arching, gun motion)	Reduce pressure. Adjust to proper distance. Too fast. Move at moderate pace, parallel to work surface.
<b>Dry spray</b>	Air pressure too high. Gun tip too far from work surface. Gun motion too fast. Gun out of adjustment.	Decrease air pressure. Adjust to proper distance. Slow down. Adjust.
<b>Fluid leaking from packing nut</b>	Packing nut loose. Packing worn or dry.	Tighten, do not bind needle. Replace or lubricate.
<b>Fluid leaking or dripping from front of gun</b>	*Foreign matter in tip. Packing nut too tight. Dry packing. Fluid tip or needle worn or damaged. Fluid needle spring deformed or broken.	Clean. Adjust. Lubricate. Replace tip & needle with lapped sets. Replace.
<b>Runs and sags</b>	Too much material flow. Material too thin. Gun tilted on an angle.	Adjust gun or reduce fluid pressure. Mix properly or apply light coats. Hold gun at right angle to work and adapt to proper gun technique.
<b>Thin, sandy coarse finish Drying before it flows out</b>	Gun too far from surface. Too much air pressure. Improper thinner being used.	Check distance. Normally 6-8". Reduce air pressure and check spray pattern. Follow paint manufacturer's mixing instructions.

\* Most common problem.











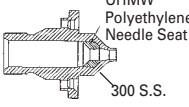
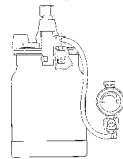

**TROUBLESHOOTING (cont'd)**

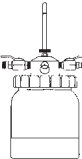
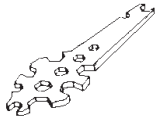
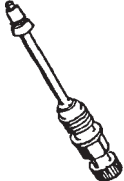
CONDITION	CAUSE	CORRECTION
Thick, dimpled finish (orange peel). Too much material coarsely atomized.	Gun too close to surface. Air pressure too low. Improper thinner being used. Material not properly mixed. Surface rough, oily, dirty.	Check distance. Normally 6-8". Increase air pressure or reduce fluid pressure Follow paint manufacturer's mixing instructions. Follow paint manufacturer's mixing instructions. Properly clean and prepare.
Excessive fog	Too much, or too fast-trying thinner. Too much atomization air pressure.	Remix properly. Reduce pressure.
Unable to get round spray	Fan adjustment screw not seating properly. Air cap retaining ring loose.	Clean or replace.  Tighten.

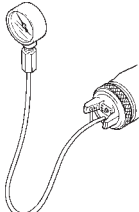
\* Most common problem.

**ACCESSORIES**

<p><b>KB-555 Alum.&amp; KB-545-SS S.S. 2 Qt Pressure Feed Cups</b></p>  <p>Includes a 0-30 psi gauge.</p>	<p><b>JGA-4051, JGA-4056 (D, E, FF, FX) Premium Fluid Tip/Needle Sets</b></p>  <p>Constructed of 300 S.S. with U.H.M.W. polyethylene needle seat. Provides extended life and better sealing characteristics. See Chart 2.</p>	<p><b>TLC-576 Aluminum Cup (PTFE Lined) &amp; TSC-591 Stainless Steel Cup</b></p>  <p>1 Qt. pressure feed cups. 3/8" NPS (F), cam lock lid. Requires KK-4980.</p>	<p><b>VS-531 Low Pressure Fluid Strainer 100 Mesh Screen</b></p>  <p>This strainer provides a final filter for trapping foreign particles in the paint supply.</p>	<p><b>MSA-4-K10 Fluid Needle Spring (replaces MBD-19)</b></p>  <p>Provides reduced spring force (4 lbs. verses 6 lbs.) for easier trigger pull.</p>	<p><b>JGA-444 Fluid Tube</b></p> <p>This tube combines the fluid and air hoses at gun handle preventing dragging hoses over work, twisting lines and improving overall gun handling.</p>
<p><b>Millennium 3000 Twin Cartridge Paint Spray Respirator</b></p>  <p>NIOSH-Certified, for respiratory protection in atmospheres not immediately dangerous to life.</p>	<p><b>Spray Gun Lube SSL-10 (2 oz. bottle)</b></p>  <p>Compatible with all paint materials: contains no silicone or petroleum distillates to contaminate paint. MSDS available upon request.</p>	<p><b>HD-503 SolventSaver®</b></p>  <p>2 Quart Hose Cleaner used to clean the inside of hose and material passages of gun. Other sizes available.</p>	<p><b>WR-103 Wrench</b></p>  <p>Contains all necessary tip, hose and nut sizes used on or with gun.</p>	<p><b>JGA-4005 Air Adjusting Valve</b></p>  <p>Allows air adjustment at the gun. Replaces JGA-132 plug.</p>	<p><b>42882-214-K5 (3/8"), 42884-215-K10 (5/8") Cleaning Brushes</b></p>  <p>These brushes are helpful in cleaning threads and recesses of gun body.</p>
<p><b>Quick Disconnect Approved for HVLP Guns (Air) High Flow Type</b></p>  <p>HC-4699 1/4" NPT(M)    HC-4700 1/4" NPT(F)    HC-4419 1/4" NPS(F)    HC-1166 1/4" NPT(M)</p>				<p><b>Air Cap Test Kit</b></p> <p>KK-5033-28 for JGHV-101-28 KK-5033-33A for JGHV-101-33A KK-5033-46MP for JGHV-101-46MP KK-5033-83MP for JGHV-101-83MP</p>  <p>The purpose of this test kit is to measure air cap atomizing air pressure at the center air port of the air cap. Used to confirm code compliance and as a daily quality control measure.</p>	<p><b>29-3100 Scrubs® Hand Cleaner Towels</b></p>  <p>Scrubs® are a pre-moistened hand cleaner towel for painters. No water is needed.</p>
<p><b>JGA-4035-K5 Optional 3 Piece Packing</b></p>  <p>This 3 piece packing can be used in place of Ref. (22) JGV-463, 2 piece packing.</p>	<p><b>MSV-457-46 Optional Baffle</b></p>  <p>For use with 46MP air cap. Eliminates need of using SSG-8182-K5 O-Ring Ref. No. 5.</p>				

**WARRANTY** This product is covered by DeVilbiss' 1 Year Limited Warranty.

**DeVilbiss Worldwide Sales and Service Listing: [www.devilbiss.com](http://www.devilbiss.com)**

**Industrial Finishing**

DeVilbiss has authorized distributors throughout the world. For technical assistance or the distributor nearest you, see listing below.

**U.S./Canada Technical Service Office:**

195 Internationale Blvd., Glendale Heights, IL 60139  
Toll-Free Telephone: 1-888-992-4657 (U.S.A. and Canada only)  
Toll-Free Fax: 1-800-368-8401

